

**MF/ME SERIES**

**AC MOTOR START  
CAPACITORS**

**MF SERIES: SINGLE ALUMINIUM CAN CONSTRUCTION  
ME SERIES: DOUBLE ALUMINIUM CAN CONSTRUCTION**

Aluminium Electrolytic Motor Start Capacitors Consisting of high purity Etched and Formed foil interlaced with condenser grade absorbent insulating paper soaked with electrolyte and are encapsulated in Aluminium Can. **MF SERIES** Capacitors are with rubber Bakelite cover with vent and solder lugs used as terminals and are provided with green colored sleeve. **ME SERIES** are MF Capacitors insulated in an outer Aluminium Can (Double Can Construction) and tinned copper wire with or without eyelets are provided to take out the connection.

The intended use is for generating starting torque in single-phase motor when connected in series with the starting coil of the motor and upon reaching near the synchronous speed the Capacitor is disconnected. The intended application is for intermittent duty cycle of 0.84%.

**1. SPECIFICATIONS**

Series	(i) MF series Single can construction with green coloured sleeve. (ii) ME Series –Double can construction with outer Aluminium Can.
Type	Aluminium Electrolytic Motor Start.
Reference Standard	IS 2993/ IEC 252
Operating Temperature	-30 <sup>0</sup> C to +70 <sup>0</sup> C
Working Voltage	(i) 110 AC Single phase 50/60 Hz (150 VAC surge) (ii) 230V AC Single phase 50/60 Hz (275 VAC surge) (iii) 330V AC Single phase 50/60 Hz (400 VAC surge)
Capacitance Range	20µF to 350µF (Capacitance will be within specified limits of minimum and maximum value when measured at 27 <sup>0</sup> C)
Power factor	Power factor shall be determined by recording current in amperes within 3 seconds after application of rated voltage and power in watts within 4 seconds after application of test voltage. Power factor shall not exceed 10% at rated voltage & frequency.
Duty cycle	30 start per hour maximum. Each start shall be of not more than 1 seconds per 2 minut duration at rated voltage confirming to 0.8% duty cycle. Other duty cycles are available on special request.
High voltage withstand Test	Capacitors shall be capable of withstanding without breakdown for 60 seconds a test between terminals and the case with 2000V sinusoidal AC Voltage of 50Hz. If the outer case is metal, the voltage is applied between the outer case and the terminals and if the outer case is insulating material a metal foil is wrapped tightly round the case and the voltage is applied between foil and terminals.

**2. OTHER INFORMATION**

Type of Packing and Lead Configuration	Bulk packing. Lead out provided using wire assembly with or without Eyelet. For details of packing refer section 10.
Capacitor Codification System	Refer section 7 for details.
Dimensional Specification	Refer section 5(a) for MF series and 5(b) for ME series
Marking Specification	Refer section 8 for details

**MF/ME** SERIES

**3. SCHEMATIC TEST SET UP FOR MEASURING CURRENT AND DETERMINATION OF POWER FACTOR AND CAPACITANCE:**

**Capacitance:**

Capacitance shall be determined by recording current within 3 seconds after the application of rated voltage at temperature 27°C as per the schematic set up in figure 1.

$$C = \frac{I \times 10^6}{2 \times 3.14 \times f \times V}$$

Where

- C = Capacitance in μF
- I = Current in Ampere
- f = Frequency in Hz
- V = Applied line voltage.

**Power Factor:**

Power factor shall be determined by recording current in Amperes within 3 seconds and power in watts within 4 seconds after application of rated voltage in the setup in figure 1.

$$PF (\%) = \frac{P \times 100}{V \times I}$$

- Where PF= Power Factor in %
- P = Power in Watts
- V = Applied Voltage in Volts
- I = Current in Amperes

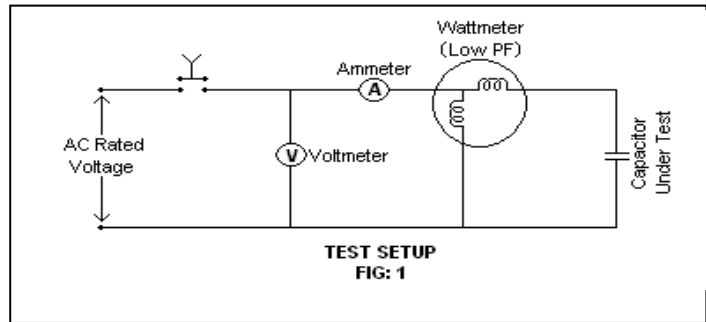

**4. PHYSICAL OUTLINES – MF SERIES & ME SERIES**

**MF Series**

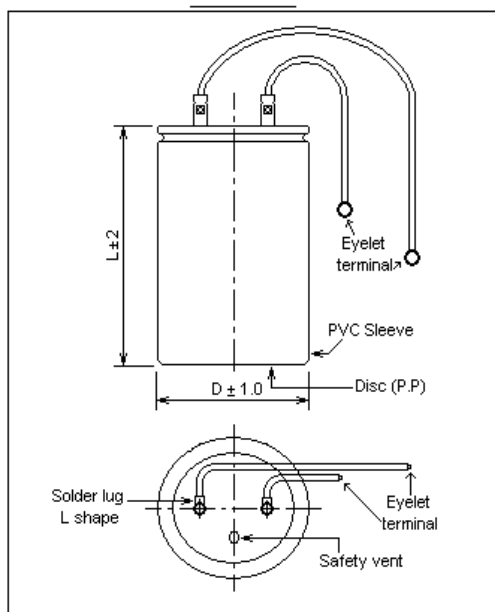

**ME Series**

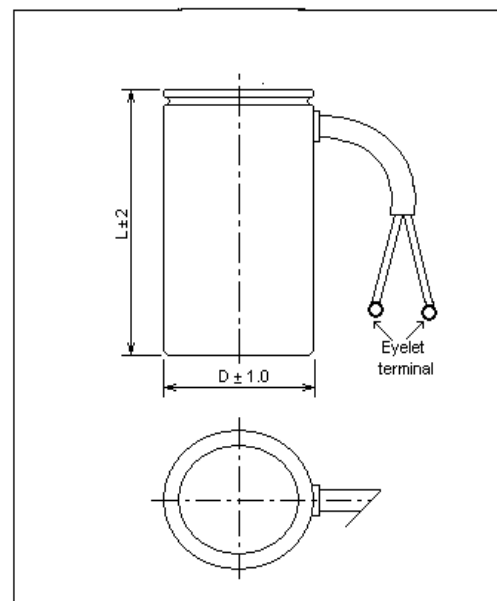

All Dimensions in mm

**MF/ME SERIES**

**5. DIMENSIONS** (All units in mm)

**(a) MF Series**

Case Code	Diameter D ± 1.0	Length L ± 2	Pitch P ± 0.2
CG	30	55	12
DG	35	55	14
DK	35	70	14
EK	40	70	16
EQ	40	100	16
FQ	45	100	18

**(b) ME Series**

Case Code	Diameter D ± 1.0	Length L ± 2
DL	35	75
EL	40	75
EP	40	95
FP	45	95
FS	45	125

**6. STANDARD RATING TABLE**

**(a) MF Series**

Rated Line Voltage: 230 VAC					
PART NO.	CAPACITANCE RANGE (µF)	CASE SIZE		CASE CODE	CURRENT (AMPS)
		Ø D mm	Lmm		RANGE AT 50Hz
MF 200 2Z A CG E0	20 ~ 25	30	55	CG	1.44 ~1.80
MF 300 2Z A DG E0	30 ~ 40	35	55	DG	2.16~ 2.88
MF 400 2Z A DG E0	40 ~ 60	35	55	DG	2.88 ~ 4.33
MF 500 2Z A DG E0	50 ~ 63	35	55	DG	3.61 ~ 4.55
MF 600 2Z A DG E0	60 ~ 80	35	55	DG	4.33 ~ 5.77
MF 800 2Z A DK E0	80 ~ 100	35	70	DK	5.77 ~ 7.22
MF 101 2Z A DK E0	100 ~ 120	35	70	DK	7.22 ~ 8.66
MF 121 2Z A DK E0	120 ~ 150	35	70	DK	8.66 ~ 10.83
MF 121 2Z A EK E0	120 ~ 150	40	70	EK	8.66 ~ 10.83
MF 151 2Z A EQ E0	150 ~ 200	40	100	EQ	10.83 ~ 14.45
MF 201 2Z A EQ E0	200 ~ 250	40	100	EQ	14.45 ~18.05
MF 281 2Z A FQ E0	280 ~ 350	45	100	FQ	20.23 ~ 25.29

**(b) ME Series**

Rated Line Voltage: 230 VAC					
PART NO.	CAPACITANCE RANGE (µF)	CASE SIZE		CASE CODE	CURRENT (AMPS)
		Ø D mm	Lmm		RANGE AT 50Hz
ME 200 2Z A DL E0	20 ~ 25	35	75	DL	1.44 ~1.80
ME 300 2Z A EL E0	30 ~ 40	40	75	EL	2.16~ 2.88
ME 400 2Z A EL E0	40 ~ 60	40	75	EL	2.88 ~ 4.33
ME 600 2Z A EL E0	60 ~ 80	40	75	EL	4.33 ~ 5.77
ME 800 2Z A EP E0	80 ~ 100	40	95	EP	5.77 ~ 7.22
ME 101 2Z A EP E0	100 ~ 120	40	95	EP	7.22 ~ 8.66
ME 121 2Z A EP E0	120 ~ 150	40	95	EP	8.66 ~ 10.83
ME 121 2Z A FP E0	120 ~ 150	45	95	FP	8.66 ~ 10.83
ME 151 2Z A FS E0	150 ~ 200	45	125	FS	10.83 ~ 14.45
ME 201 2Z A FS E0	200 ~ 250	45	125	FS	14.45 ~18.05

# MF/ME SERIES

## 7. CAPACITOR ORDERING INFORMATION

Capacitors are identified with the help of a 12-digit code. Expansions of Part Nos. are detailed below.

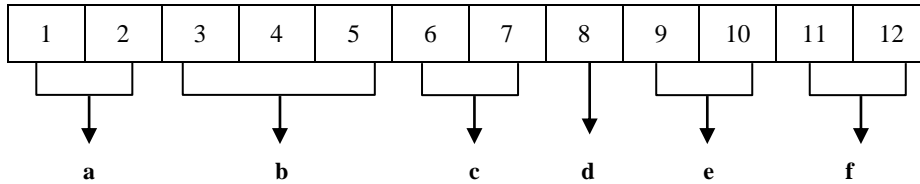

a	b	c
<b>Series Code</b>	<b>Min Capacitance Value Code</b>	<b>Voltage Code</b>
MF : Single Can ME : Double Can	Eg: (i) 20 $\mu$ F is coded as 200 (ii) 280 $\mu$ F is coded as 281 (For the range of Cap. Refer rating table)	110 VAC – 2N 220 VAC – 2R 230 VAC – 2Z 330 VAC – 2Q
d	e	f
<b>Capacitance Tolerance Code</b>	<b>Size Case Code</b>	<b>Capacitor lead wire Termination Code</b>
A: Special Tolerance (within specified limits of Minimum & maximum value provided in the rating table)	For MF: CG to FQ (refer Dimension Table 5a) For ME: DL to FS (refer Dimension Table 5b)	Provided by the factory based on customer requirements. Eg: BO: wire assembly without eyelet EO: wire assembly with eyelet

Example (i) MF Series 20- 25 $\mu$ F/ 230V  
Wire assembly without eyelet

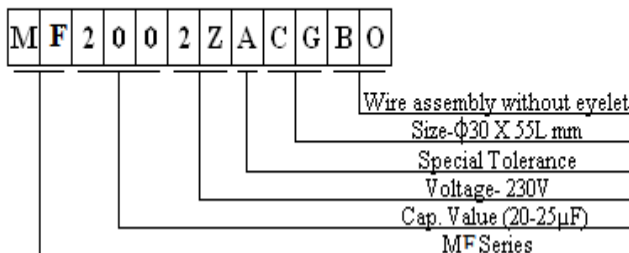

Example (ii) ME Series 60-80 $\mu$ F  
Wire assembly with eyelet

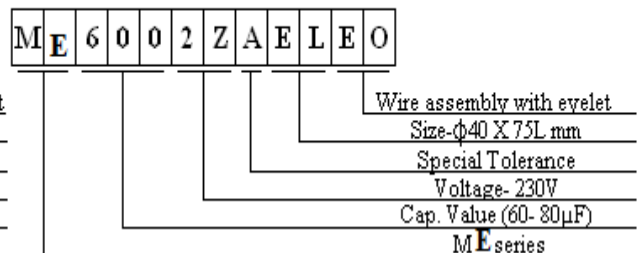

# MF/ME SERIES

## 8. MARKING ON THE CAPACITOR

For AC Aluminium Electrolytic Capacitors MF series product information is printed on green coloured vinyl sleeve with black letters and for ME series product information is printed in adhesive labels affixed to the outer can. Hologram is also affixed to the outer can of ME series capacitors.

The following information are marked on the capacitor

- a) Capacitance type (A.C. MOTOR START)
- b) Rated capacitance range in  $\mu\text{F}$  & Rated voltage in V
- c) Surge voltage (SV) and rated frequency in Hz
- d) Temperature category in  $^{\circ}\text{C}$
- e) Duty cycle in %
- f) Manufacturer's name & logo **KELTRON®**
- g) Date code (Year – Month)

## 9. DATE CODE

Year code for MF & ME

Year	2000	2001	2002	2003	2004	2005	2006	2007	2008	2009
Letter Code	M	N	P	R	S	T	U	V	W	X

Year	2010	2011	2012	2013	2014	2015	2016	2017	2018	2019
Letter Code	A	B	C	D	E	F	H	J	K	L

Year code repeats after each cycle of 20 years

Month code for MF & ME

Month	Jan.	Feb.	Mar.	Apr.	May	Jun.	July	Aug.	Sept.	Oct.	Nov.	Dec.
Character code	1	2	3	4	5	6	7	8	9	0	N	D

## 10. PACKING QUANTITY

Motor Start Capacitors are generally packed in primary cardboard cartons by employing suitable SEPARATORS to avoid damage during transit. The primary cartons are then inserted into MOTHER cardboard cartons before shipment. Packing quantities in numbers per primary carton are detailed below.

### MF Series

Case Code	Nos. / Carton
CG	100
DG	81
DK	81
EK	64
EQ	64
FQ	49

### ME Series

Case Code	Nos. / Carton
DL	81
EL	64
EP	64
FP	49
FS	49